



# YOUTH VOLLEYBALL PROGRAM





Dear Coaches,

We want to express our deepest appreciation for your incredible dedication to the City of Rialto and your unwavering commitment to our youth through your involvement in our youth sport programs.

Understanding the vital role, you play as mentors and leaders, we have developed the following Code of Conduct to guide your actions and ensure the positive development of our young athletes:

- 1. Inclusivity:** Embrace and foster an inclusive and welcoming environment within our youth sport programs. Treat all players, regardless of their background, gender, race, or skill level, with respect, fairness, and equal opportunities. Encourage teamwork, empathy, and a sense of unity among all participants.
- 2. Mentorship:** As coaches, you have the power to make a lasting impact on the lives of our young athletes. Strive to be positive role models, displaying integrity, sportsmanship, and professionalism always. Foster personal growth by actively helping players develop their skills, both on and off the field. Encourage them to overcome challenges and set high standards for themselves.
- 3. Building Confidence:** Place a strong emphasis on building the confidence and self-esteem of our players. Celebrate their achievements, no matter the size, and provide constructive feedback that helps them grow. Encourage a growth mindset, where mistakes are viewed as opportunities for learning and improvement. Empower players to believe in themselves and their abilities.
- 4. Respecting League Policies and Practices:** Familiarize yourself with the rules, policies, and practices established by the league. Adhere to these guidelines and ensure that your coaching staff, players, and parents are aware of and respect them as well. By doing so, we create a fair and consistent environment for everyone involved.
- 5. Accountability:** Hold yourself accountable for your actions and behaviors as a coach. Set clear expectations for your coaching staff, players, and parents regarding their conduct during games and practices. Foster open communication, address concerns promptly and professionally, and promote an environment of mutual respect and teamwork.
- 6. Zero Tolerance for Disrespect:** We have a zero-tolerance policy for any form of blatant disrespect towards league rules, league staff, coaches, players, parents, or community members. Such behavior undermines the values and principles we strive to uphold and will result in severe consequences. Any violations may lead to disciplinary actions, including suspension or removal from coaching duties.

Once again, we extend our deepest gratitude for your selfless service and dedication. Your commitment to the City of Rialto and our youth is invaluable. By following this Code of Conduct, we can continue to create an environment that instills the values of respect, sportsmanship, and personal growth. Together, let us empower our young athletes to become confident, resilient, and respectful individuals.

Thank you for your ongoing support and invaluable contributions.

## **City of Rialto**

### **Parks, Recreation & Community Services**

#### **Rules and Regulations**

### **Program Philosophy**

The main purpose of the City of Rialto Youth Volleyball Program is to provide a positive and fun experience for everyone involved, (i.e. coaches, parents, spectators, officials, and most of all the boys and girls participating).

These goals can be reached, even without a winning season. Simply by emphasizing fun, skill development, and the excitement of competition, you'll have a successful season.

Our philosophy of Youth Volleyball is patterned after our belief that sports can play an integral role in the growth and maturation of everyone involved. The development of a person's skill as a player coincides with the outgrowth of everyone as a human being. The guidance and direction of each child should be based on what we call, "The Truths about Children and Sports":

1. **Fun is pivotal; if it's not "Fun," young people will not play a sport.**
2. Skill development is a crucial aspect of fun; it is more important than winning even among the best athletes.
3. The most rewarding challenges of sports are those that lead to self-knowledge.
4. Intrinsic rewards (self-knowledge that grows out of self-competition) are more important in creating lifetime athletes than are extrinsic rewards (victory or attention from others).

Your success as a coach will depend more on your coaching philosophy than any other factor. In general, a coaching philosophy is a set of personal beliefs and principles that guide the actions you take with your athletes. Developing a coaching philosophy is important because it provides you with a blueprint or framework for all the decisions you make as a coach. A well-thought-out coaching philosophy helps you:

1. To identify, prioritize and organize worthwhile instructional goals for the season.
2. Offer efficiency in planning and coordination between people.
3. Most important, it gives you, your assistant, your athletes' parents, and your team a sense of values from which to work.

**Communication:** It is essential that you communicate quite regularly with the parents/guardians of your team members; providing information in writing helps immensely. All communication needs to be through the Team sideline messaging app. Coaches are not allowed to create group text messages to ensure that numbers are not being shared and for all privacy reasons.

**Preparation:** It is equally important to be prepared for the task at hand whether it is practicing or getting ready for a game. Being prepared encompasses a wide variety of fundamental issues such as practice organization, proper equipment, rule knowledge, and program philosophy.

**Safety:** A thorough knowledge and understanding of good safety procedures will eliminate common injuries and accidents. Accidents occur most frequently when players are fooling around and not paying attention to your directions. You need to be constantly aware of safety needs and concerns.

Above all remember, you are dealing with children in a child's game where the best form of motivation is enthusiasm and positive reinforcement. If the experience is FUN for you, it will also be fun for the participants on your team.

If you have any questions, please feel free to contact us. Thank you for volunteering your time and have a great time.

Railynn Frost

Recreation Programmer

909-644-7655

[RFrost@rialtoca.gov](mailto:RFrost@rialtoca.gov)

Ebony Perkins

Recreation & Community Services  
Manager

909-820-2525 ext. 8155

[EPerkins@rialtoca.gov](mailto:EPerkins@rialtoca.gov)

Alex Acosta

Recreation Aide

909-820-2559

[AAcosta@rialtoca.gov](mailto:AAcosta@rialtoca.gov)

## **Rules and Regulations**

The Southern California Federation (S.C.M.A.F.) Rules and Southern California National Federation High School rules have been adopted as stated and will apply except where the City of Rialto League rules conflict. City league rules have priority.

### **Player Eligibility**

- A. All players must register through the Parks, Recreation and Community Service Department. Players will be registering through the Active Net system online or in person. Comp players will be registered by a sport staff, if they are on the team information sheet.
- B. The following divisions will apply:
  - Division 1- Age group 12yrs – 15.11yrs
  - Division 2 - Age group 8 yrs – 11.11yrs
  - \*Ages are calculated by last day of the season.
- C. Players may play up one division. If the parents approve their players to move up a division, they must come into the office
- D. Any player found to be ineligible will be removed from the game and program immediately.
- E. Coaches who use non-registered players (ineligible players) may also face suspension or expulsion.
- F. Coaches may not recruit players for their team or presume to register players. All interested children must register through Parks, Recreation & Community Services directly.

### **Team Formation:**

- A. Every Coach must be cleared to coach; this includes assistance coach also.
  - a. Volunteer application completed, and turned into the Parks, Recreation, Community Services Department.
  - b. Scheduled finger printing at the Police Department.
  - c. Human Resource department has sent a written clearance to the Parks, Recreation, Community Services Department.
- B. Every team must turn in a team information sheet on or before coaches meeting date.
  - a. Team information sheet should include the following information:
    - i. Team information
    - ii. Coaches' information

- iii. Practice request schedule
- iv. Complementary Player information
  - 1. Each team is given 2 comp players per team.
  - 2. A parent signature is required.
  - 3. If the players have siblings and you are not comping the sibling, they may be placed on a different team.
- C. Coach's Acknowledgment Form is due before coaches get their rosters. If they have not turned one in for upcoming season, they will not receive their rosters.
- D. The program's goal is to create balanced teams. Our program's team placement process is designed to give players the opportunity to work with different teammates and coaches each season. This approach helps players develop a more well-rounded skill set, enhance their adaptability, and build connections across the league. While it may seem like frequent changes, our goal is to provide a supportive environment where players can grow and thrive both on and off the court.
- E. Division 1 has a scheduled skills assessment. During the skills assessment each player does a set of drills to show their level of passing, setting, hitting, serving and a short game play. The skill assessment is used to determine the skill level of each player. 5 being a highly skilled player and 1 being needs improvement.
- F. The program does its best to connect siblings with each other by putting them on the same practice dates. The program cannot guarantee that we connect sibling based off availability.
- G. Rosters will be emailed to coach at least by the Wednesday before the start of practices.

## How to Play Volleyball

A volleyball game consists of two teams of six players each, separated by a net. The six volleyball court positions are setter, middle blocker, outside hitter, opposite hitter, libero, and serving specialist.

\*Our league does not use a libero currently.

To start, flip a coin to determine which team serves the ball first.

Then the two teams will rally—or hit the ball back and forth over the net—until a fault occurs. There is a maximum of three hits per side.

The objective is to score points by sending the ball over the net, grounding it into the opponent's court.

Volleyball matches are made up of sets, typically three or five sets.

- **Three-set matches:** Two sets to 25 points and a third set to 15 points. Each set must be won by two points. The first team to win two sets is the winner of the match.

- Division 1 teams: The team that first scores twenty-five (25) points in a game shall win that game. A team must win by two (2) points, and there is a (27) point cap. The first team to win two games wins the match. If the match requires a deciding third game, the first team to reach fifteen (15) points with a minimum two-point lead shall win it, and there is a (17) point cap. Duration of game is fifty-minute time slot.
- Division 2 teams: The team that first scores twenty-five (25) points in a game shall win that game. A team must win by two (2) points, and there is a (27) point cap. The first team to win 2 games wins the match. If the match requires a deciding third game, the first team to reach fifteen (15) points with a minimum two-point lead shall win it, and there is a (17) point cap. Duration of game is forty-minute time slot.
- **Five-set matches:** Four sets to 25 points and a fifth set to 15 points. **No point cap for championship game. The team must win by two points unless tournament rules dictate otherwise.** The first team to win three sets is the winner. Mandatory subs in the first four set, with free subs in the fifth.
  - This is used only for Division 1 championships.
- **Minimum Play Rule: Mandatory substitution for all teams in the first and second set at 10 points for regular season games. All players on the bench will go into the game. Free substitution will be allowed if both teams adhere to substitution rules in the third set.**
  - **Coaches are required to record attendance must be every practice and game them the TeamSideline app. (an assist coach or parent can help with this)**
  - **Exceptions to the rule are:**
    - **Coach is experiencing problems with a player failing to attend practices. (Coach must notify the staff at score table before the game and show attendance sheets.) If the Sport Programmer fails to resolve problem with the parent, then the League Programmer can restrict child's playing time for the upcoming game.**
    - **Later arriving players: Players must check in at the table when they arrive. Players reporting to the table with more than the minimum minutes remaining in the quarter must meet the requirement of consecutive minutes remaining in the quarter. Players reporting to the official scorekeeper late may have to wait until the next set. Players must be dressed and ready to play at the time of check-in to play.**
    - **If a child is injured, play can be restricted but Coach must notify on-site staff prior to restricting play and staff approval. If a child is ill, he/she cannot sit on the team bench. NOTE: Coaches cannot restrict a child's playing time to less than what is established in the league rules.**

- **SUBSTITUTIONS: The official must be notified before all substitutions. There are no limits in the amount of team substitutions, or substitutions per position. However, once a player is substituted for a particular position, (s)he must play in that position for the rest of the game or until substituted by the original owner of that position. During substitutions, other players' positions must remain the same. These rules are intended to provide all participants with a maximum amount of playing time. For D-1 and D2, they get free subs at 3rd set. Players have 15 seconds to sub if they go over the time, the team loses a point.**
- Practice: If a player misses practice that player will miss the first set.
- ROSTER LIMIT: There will be a maximum of 12 player roster. Unless the league requires additional players to place.

Note: If a coach comps one sibling is not a guarantee that they will get the other sibling.

## Basic Volleyball Rules and Terms

### Volleyball Rules

1. Only 6 players on the floor at any given time: 3 in the front row and 3 in the back row.
2. Points are made on every serve for the winning team of the rally (rally-point scoring).
3. Players may not hit the ball twice in succession (a block is not considered a hit).
4. The ball may be played off the net during a volley and on a serve.
5. A ball hitting a boundary line is in.
6. A ball is out if it hits an antenna, the floor completely outside the court, any of the net or cables outside the antennae, the referee stands or pole, or the ceiling above a non-playable area.
7. It is legal to contact the ball with any part of a player's body.
8. It is illegal to catch, hold, or throw the ball.
9. A player cannot block or attack a serve from on or inside the 10-foot line.
10. After the serve, front-line players may switch positions on the net.
11. Matches are made up of sets; the number depends on the level of play.
12. **Service:** To legally serve the ball, a player's last contact with the ground before contacting the ball must be behind the back service line, anywhere along its length. Players must wait for the official's whistle to initiate the serve. Players have 5 seconds to serve. Players must contact the ball on their first attempt at serving or a side out will result. The ball is considered in play if the ball contacts the net before going over. However, in Division 2 players may be allowed to serve inside the court under handed; overhand server must serve behind regulation line. Players have 7 seconds to serve. Positioning: The position of the other players during service shall be within their playing area (but may not touch the court boundary lines) in serving order with each of the three forward line players in front of their respective back row players at the instant the ball is served. A player also may not overlap

an adjacent player to the left or right of his/her position. The position of players is judged according to the place their feet contact the floor at the time the ball is contacted for service.

### **Volleyball Rule Violations**

Committing any of these violations results in a point for the opponent:

- Stepping on or across the service line when serving while contacting the ball.
- Failure to serve the ball over the net successfully.
- Ball-handling errors and contacting the ball illegally (double touching, lifting, carrying, throwing, etc.).
- Touching the net with any part of the body while the ball is in play.
- Blocking a ball coming from the opponent's court and contacting the ball when reaching over the net if your opponent has not used 3 contacts AND has a player there to make a play on the ball.
- Attacking a ball coming from the opponent's court and contacting the ball when reaching over the net when the ball has not yet broken the vertical plane of the net.
- Crossing the court centerline with any part of your body, except for a hand or foot. It is only considered a violation if the entire hand or entire foot crosses the court centerline.
- Serving out of rotation or out of order.
- Back row player blocking (deflecting a ball coming from the opponent) when, now of contact, the back row player is near the net and has part of their body above the top of the net (illegal block).
- Back row player attacking a ball inside the front zone (area inside the 3M/10-foot line) when the ball is completely above the net (illegal attack).

### **Indoor Volleyball Court Dimensions**

The official indoor court dimension is 30 feet by 60 feet with an attack line 10 feet from the centerline on each side of the court.

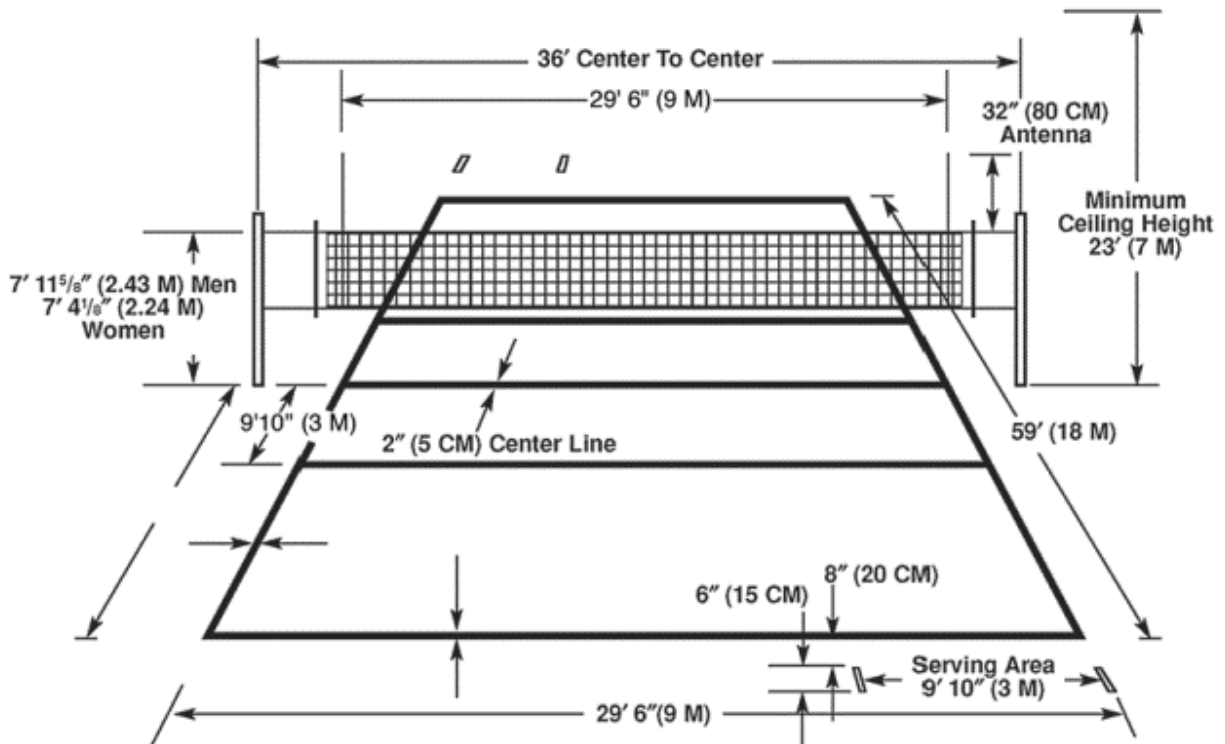

## Coaching Expectations

As a coach, you are a role model. We expect you to:

- Arrive prepared for all practices and games.
- Communicate effectively with players, parents, and staff.
- Promote a positive and inclusive environment.
- Emphasize skill-building, teamwork, and fun over winning.
- Follow all City of Rialto policies and procedures.

## Code of Conduct

Coaches must adhere to the highest standards of behavior, including:

- Respecting all players, officials, and parents.
- Avoiding any form of discrimination or harassment.
- Addressing conflicts constructively and professionally.
- Setting a positive example both on and off the court.

## Player Development Goals

Focus on developing players in these areas:

- **Technical Skills:** Passing, serving, setting, hitting, and blocking.
- **Game IQ:** Understanding game rules, positions, and strategies.
- **Sportsmanship:** Respecting opponents, teammates, and officials.
- **Confidence:** Encouraging self-belief and resilience.

### Practice Guidelines

- **Planning:** Prepare a structured practice plan.
- **Duration:** Practices should last 50-60 minutes, depending on the age group.
- **Warm-Up:** Include dynamic stretching and volleyball-specific drills.
- **Skill Drills:** Focus on one or two key skills per practice.
- **Scrimmage:** Allocate time for game-like scenarios.
- **Cool Down:** Finish with stretching and a brief team discussion.
- If practices are canceled, please let the office and your team know 24 hours before the canceled practice is scheduled
- Please remember that we use shared practice space. Do not have your player warming up or stretching inside during another team's practice time, please have your player go outside until their practice time. At the end of practice please take a team talk outside and leave the court clean for the next team.

### Game Day Procedures

- **Arrival:** Coaches and players should arrive at least 30 minutes before the game.
- **Warm-up:** Team can warm-up on the outdoor basketball courts.
- **Roster Check:** Ensure all players meet eligibility requirements.
- **Equipment:** Verify proper equipment and uniforms.
- **Post-Game:** Lead a team huddle to discuss positives and areas for improvement.

### Safety Policies

- **Injuries:** Prioritize player safety. Follow proper protocols for injuries.
- **Equipment Checks:** Inspect all equipment for safety before use.
- **Hydration Breaks:** Provide frequent water breaks, especially in warm weather.
- **First Aid:** Familiarize yourself with first-aid procedures and locations of first-aid kits.

### Parent Communication

- Hold a preseason meeting to outline expectations and schedules.
- Use clear, timely communication methods (email, texts, or team apps).
- Address concerns promptly and professionally.

- Encourage positive parent involvement and support.

#### Gym rules for the rialto unified school district

1. No food or drinks are allowed in **any** R.U.S.D. gym at any time
2. All chairs, tables and equipment must have non-marking legs or bottoms, otherwise it is not allowed
3. No gum or tobacco products are allowed on any campus at any time.
4. No campus parking. Lots are marked and designated for all campus visitors.
5. All gyms must be clean of all debris before exiting the facility(s)
6. Patrons are allowed in designated areas only
7. Outside lunch and table areas must be cleaned before leaving campus
8. All patrons will enter and exit facility(s) as instructed
9. All children must be always supervised while at facility
10. All patrons must use designated restroom facilities

Coaches, please monitor your teams. We are guests of the rialto unified school district. As we want our program to grow, we must make sure we continue to build lasting relationships of trust. The district has entrusted us with the use of their facility. We thank them for adhering to their rules and regulations.

#### **Rialto Carl Johnson Center Gym Guidelines**

1. No Personal Balls on Game Days: Avoid bringing personal balls to the gym on game days. Only coaches may bring balls for pregame warm-ups.
2. Zero Tolerance for Inappropriate Behavior: Profanity, fighting, bullying, or name-calling is not permitted.
3. No Heckling: Refrain from heckling officials, players, coaches, or staff.
4. Respectful Communication: Address issues with staff in a respectful and professional manner.

5. Avoid Crossing in Front of Benches: Go around rather than crossing in front of team benches.
6. Stay on Designated Spectator Areas: Remain on the bleachers side, avoiding the players' side and staff areas.
7. No Sideline Coaching: Parents, please refrain from sideline coaching to support the coach's role.
8. Encourage Good Sportsmanship: Cheer for both teams and discourage actions that may negatively affect players. Unsportsmanlike behavior will not be tolerated.
9. Shirts and Shoes Must Be Worn at All Times.
10. No Hanging on the Rim: Strictly prohibited for safety reasons.
11. No Sitting on the Stage: Avoid sitting on the stage area.
12. No Foul Language: Always use appropriate language.
13. Keep Pathways Clear: Do not block doorways or walkways.
14. Clear the Court: Keep the court clear during halftime, timeouts, and between games.
15. Closely Monitor Children: Keep a close eye on all children under your care and prevent disruptive behavior.
16. Non-Mark Shoes: Only non-marking shoes are allowed on the court.
17. Maintain Cleanliness: Food and drink are permitted, but please dispose of trash properly to keep the gym clean. Use designated trash cans for proper disposal.

***The City of Rialto and its staff are not responsible for lost or stolen items. Let's focus on the kids having fun, and adults are urged to avoid behavior that could disrupt the league. We reserve the right to expel anyone from the gym or involve the authorities if they engage in any conduct unbecoming to the league***

## **Coach's Acknowledgment Form**

I, \_\_\_\_\_,  
confirm that I have read, understood, and

will abide by the rules and regulations outlined in the City of Rialto Youth Volleyball Program Handbook.

**Coach Signature:**

---

**Date:** \_\_\_\_\_