



PRACTICES

U4 practices should not exceed 45 minutes.

U6, U8, U10, U12, Jr. High, and High School practices should not exceed one hour.

Be organized yet flexible with practice plans – plan ahead of time

- Warm up with light cardio
- Plenty of activity
- Maximum use of time, facility, and equipment
- Progress from simple to complex
- Make it a safe and fun environment for all

Give Explanations

- Clear and concise
- Short and to the point
- Be enthusiastic

Give Demonstrations

- Clearly visible and seen by all
- Repeated multiple times from all angles
- Ensure each player gets the same amount of attempts

Recruit parents to help during practice.

Always be positive, encouraging, and constructive.

Encourage athletes to arrive 10-15 minutes before practice time.

Leave the gym, court, field, and/or facility better than you found it.

- Double check that you have all of your personal belongings
- Make sure there is no trash left behind
- If there is a spill, tell a YMCA Staff member immediately



PRACTICES

SAMPLE PRACTICE PLAN 1

SKILL	DRILL	NOTES
Warm Ups and Conditioning	<ul style="list-style-type: none">• Running (to the other side and back)• Hopping (to the other side and back)• Skipping (to the other side and back)• Bear crawl (to one side, then do crab walk back)• Running (to the other side and back)	5-10 minutes
WATER BREAK		
DRIBBLING	<ul style="list-style-type: none">• Introduce dribbling• Strong arm• Dribble catch	10-15 minutes
WATER BREAK		
SHOOTING	<ul style="list-style-type: none">• Introduce shooting• Dribble down and shoot	10-15 minutes
WATER BREAK		
PASSING	<ul style="list-style-type: none">• Introduce passing• Partner passing• Monkey in the middle	10-15 minutes



PRACTICES

SAMPLE PRACTICE PLAN 2

SKILL	DRILL	NOTES
Warm Ups and Conditioning	<ul style="list-style-type: none">• Running (to the other side and back)• Hopping (to the other side and back)• Skipping (to the other side and back)• Bear crawl (to one side, then do crab walk back)• Running (to the other side and back)	5-10 minutes
WATER BREAK		
DRIBBLING	<ul style="list-style-type: none">• Review dribbling• Dribbling around cones• Red Light, Green Light	10-15 minutes
WATER BREAK		
DEFENSE	<ul style="list-style-type: none">• Introduce defense• Defensive shuffle• Dribbling around defenders	10 minutes
WATER BREAK		
PASSING	<ul style="list-style-type: none">• Introduce shooting• Dribble down and shoot	10-15 minutes
WATER BREAK		
SHOOTING	<ul style="list-style-type: none">• Review Shooting• Low post shooting	10-15 minutes



RESOURCES AND DRILLS

WARM-UPS AND STRETCHING

Begin each practice and game with static and dynamic stretching activities to get players warmed up and ready to go.

- Running
- Hopping
- Skipping
- Bear Crawl
- High Knees
- Lunges
- Back Pedal
- Step Slide
- Dribble while Walking
- Dribble while Jogging

RESOURCES AND DRILLS

FITNESS AND COORDINATION DRILLS

1. Sprint/Jog

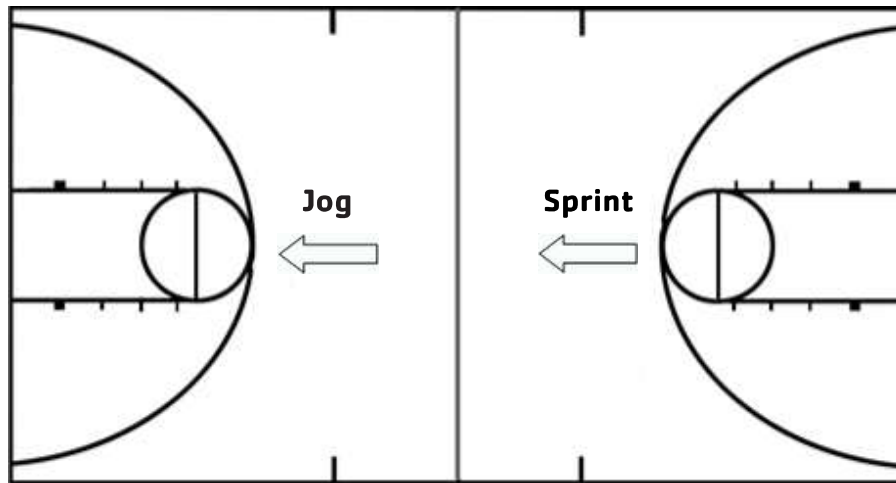

2. Relay Race

Break players into 2 teams. Have players line up on the baseline.

Examples: running, bunny hops, skipping, dribbling, etc.

3. Simon Says

"Coach Says"

4. Line Sprints

Start at the baseline, sprint to the free throw line, then back to the baseline, half court and back, free throw line on opposite side and back, baseline and back.

5. Circle Basketball Around Waist

While players are standing, have them circle their ball repeatedly without dropping the ball.

6. Circle Basketball Around Legs

While players are standing, have them circle their ball repeatedly without dropping the ball.

7. Throw Ball in the Air and Catch

Players are standing facing coach. On coaches cues, players will throw the ball in the air. Start with players throwing ball at low height, then progressively get higher.

Intermediate players clap while the ball is in the air, then catch it

8. Intermediate Players Box Run

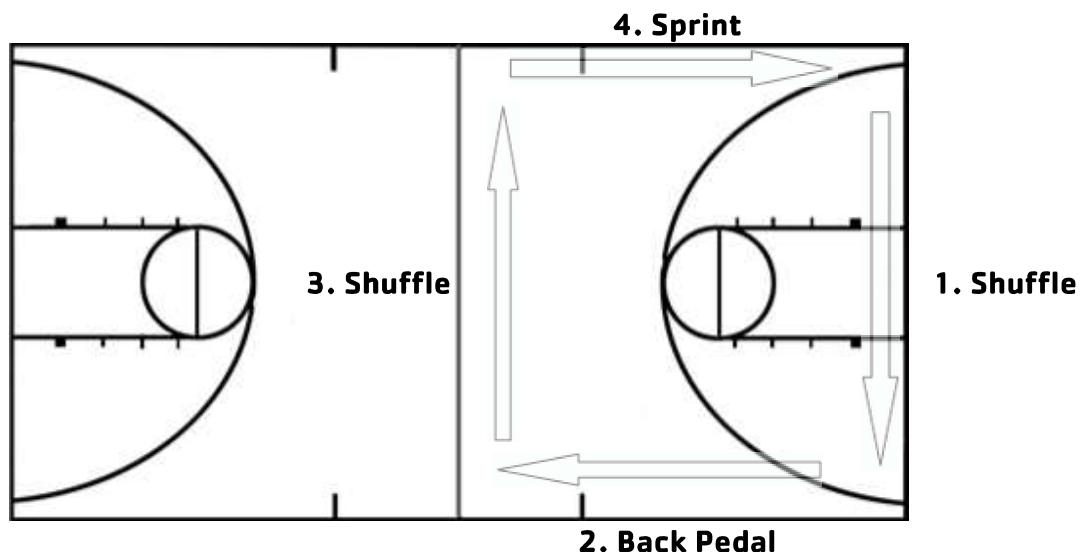



RESOURCES AND DRILLS

HOW TO DRIBBLE

Young children's dribbling skill levels will vary. For the younger age groups, dribbling is best learned through doing rather than standing around and watching. Be mindful not to over-coach, teaching dribbling to young children is easier than many coaches make it.

1. To start, simply ask the question, "What is dribbling?" Allow them to dribble where they are standing. Even children that don't dribble well are eager to help show what they think dribbling is. Give them your attention during this time. For fun, follow with another question, "Are you sure that is dribbling?"
2. After several minutes, get the players to begin moving up and down the court. This is where a child may be hesitant and say, "I can't dribble." Encourage them to walk with the group. Encourage them to simply bounce the ball once and catch it.
3. Ask the players to "show me your muscles." Be sure to demonstrate the Strong-Arm position.
4. Ask them, "Can you create a Strong-Arm straight out in front of you?" Next you will tell them, "I am going to come around and check your strong arm." This requires tapping on the top of the arm of each child to make sure it doesn't drop. As you do this say, "Yep, that is a Strong-Arm! Good Job!" After you've done this have some fun and humor them by having one child push down on your arm. Let it fall, then flop it up and down and tell them, "No, noodle arms."

Before leaping into getting them to demonstrate how to dribble with their Strong-Arm, have them walk up and down the court with their Strong-Arm up. Tell them to pick up their basketballs and hold it on their pocket. No dribbling, on your cue children will just walk. Young children's arms have a tendency to get tired so you must gently encourage them as they walk to keep their Strong-Arm up.

5. Add the dribble. Tell them, "put the basketball on your pocket and hold up your strong arm." Once they are all in position, tell them, "keeping two feet on the (base)line, dribble keeping your strong arm UP." Do not be afraid to stay with static dribbling until children exhibit confidence in what they are doing. Go over dribbling with finger pads.
6. Once they are ready, get them moving up and down the court. Encourage and praise the strong arm.

Coach's Cues

"Strong Arm"

"Use your finger pads"

"Keep the ball low"

"Keep the ball at your side"



RESOURCES AND DRILLS

DRIBBLING DRILLS AND GAMES

- 1. Dribble Catch**
 - A. Introduce, demonstrate and explain how to dribble
 - B. Have your players practice dribbling without losing control
 - C. Introduce the rules on traveling and double dribble
 - D. Players should stand apart from each other (allow 15 seconds for them to move to their own space).
 - E. On a signal, they begin dribbling around the court without losing control. Players stop and catch the ball quickly on a signal.
 - F. Repeat three times using short intervals (20, 30, and 45 seconds).

- 2. Red Light, Green Light**
 - A. Red Light: Means Stop. The players dribble the ball while standing in one place.
 - B. Green Light: Means Go.
 - C. Yellow Light: Means Slow Down.

- 3. Strong Arm**

The kids DO NOT dribble but instead focus on creating their Strong-Arms. Each child will try to knock the ball out of another child's hand while protecting his own ball using his Strong-Arms.

- 4. Dribbling Around Cones**

Setup cones every 5 yards (4-5 cones). Form the cones in a line or zig-zag. You can have the player shoot at the basket when they pass the last cone or make the game into a relay race. The first team to finish dribbling through the cones, shoot and then sit in a straight line wins the game.

- 5. Dribbling Around Defenders**

Split your team in two. Have the first group stand in a straight line 5 feet apart. These players are defenders and can not move their feet, but can move their hands. The second group will dribble the ball between the first group in a weaving pattern. Then switch groups.

- 6. Follow the Leader**

Without a basketball, the coach or players can jump, run, skip, hop, etc. With a basketball, the coach or players can dribble with left or right hand, cross-over, dribble while walking backwards, etc.

- 7. Duck, Duck, Goose**

Players sit in a circle with one basketball in the middle, and one person is it. The person who is it will go around the circle tapping players' heads saying "Duck, duck, duck, goose". The player who gets tapped goose will grab the basketball, dribble to the basket, shoot and try to make a basket before the person who tagged them gets the ball.

RESOURCES AND DRILLS

DRIBBLING DRILLS AND GAMES

8. Sharks and Minnows

Start with one player as the "shark". The rest of the players are "minnows". Minnows will have a basketball and will try to make it to the other side without the sharks getting their basketballs.

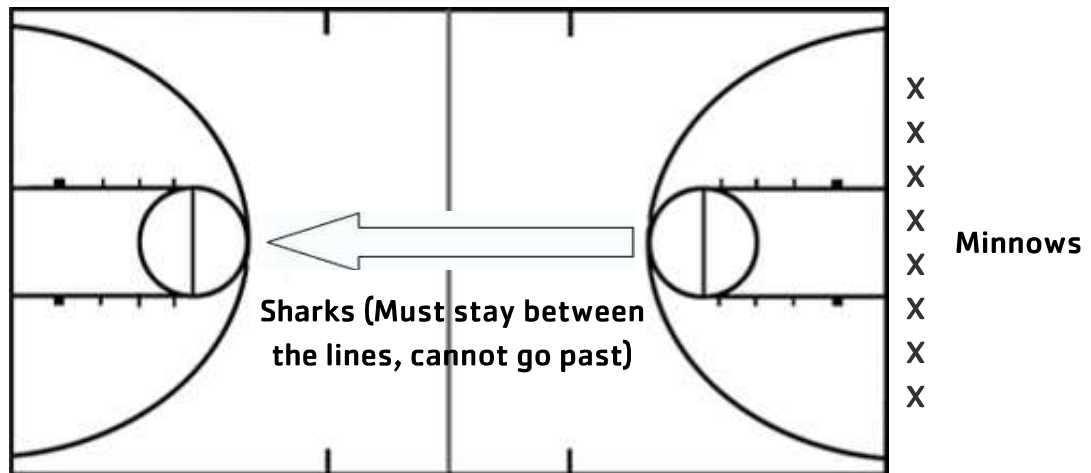

9. Righty - Lefty

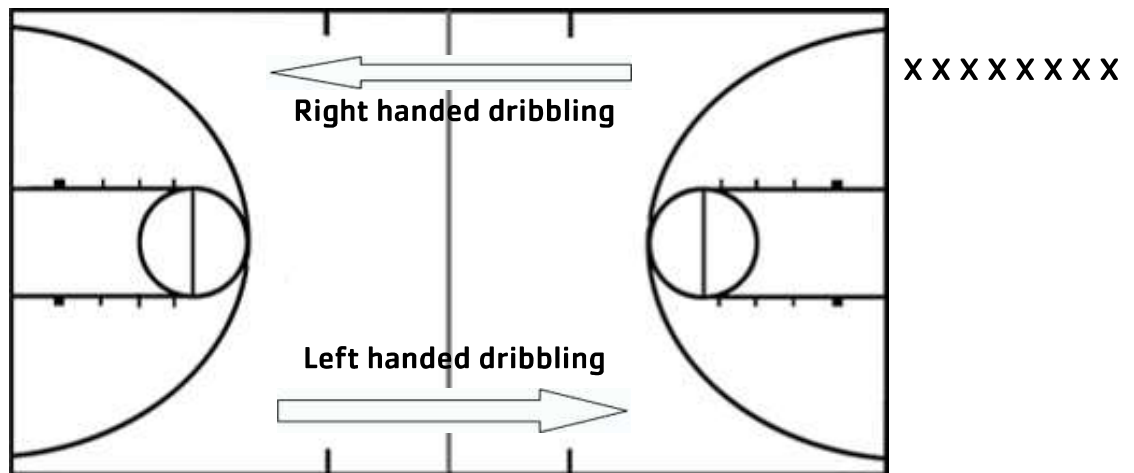

10. Change Direction Drill

To start this game, the coach turns his/her back to the team and begins to walk up the court. As the coach's back is turned, the players should dribble their basketball down the court after the coach. The coach should then turn to face the players and chase them back to the starting line. Once the coach turns, the players should stop, reverse direction and quickly dribble the ball back to line.



RESOURCES AND DRILLS

HOW TO SHOOT

1. Line players up on the baseline. Start with a basketball but tell the players to put the basketball between their feet.
2. Ask, "What comes on top of a pizza?" Answer: toppings. Ask, "What is your favorite topping?" Ask, "Who has eaten pizza in a restaurant before?"
3. "How do servers in the restaurant hold the pizza when they bring it to your table?" Players may show you some variation of holding a tray. This will be known as their Pizza Position. As you demonstrate, ask "What is this called?"
4. Hold up your index finger and ask, "What is this?" Ask this several times so they can give you the most common answers. The players will tell you it is a pointer finger or the number one. You should agree and tell them they are right, but ask, "What else is it?" When you've exhausted their resolve, ask, "Isn't it your booger finger too?" This will inevitably evoke a smile. Ask players to point the booger finger on the hand that holds the pizza towards their nose. You might say, "Towards your nose, not in your nose."
5. When they are holding their pizza tray and pointing their booger finger at their nose, take the basketball from between their feet and place it on their tray. When everyone has their pizza, check their pizza position and booger finger.
6. Instruct the players to, "put your other hand on the ear of the basketball." Be sure to demonstrate to the players where the ears would be as this is where they will place their other hand when shooting.

Layups

1. Without a ball, have the players practice raising the knee and arm on the same side at the same time.
2. Have the players practice the footwork: step, step, knee and arm raise.
3. Line the players up at the free throw line with a basketball. Have the players start with their feet together. Instruct the players to: step with their right foot and dribble, then step with their left foot, pick-up their dribble, jump and shoot the lay-up.
4. Demonstrate to the players that when they are about three feet from the basket, they should stop dribbling and jump off the foot closest to the basket. As they jump towards the basket, make sure they know their other knee should come up towards their chest.
5. Show them how to throw their basketball at the backboard square. This will allow them a better opportunity to make a lay-up.
6. Have the players start on the blocks, move to the free throw line, then move to the three point line. This will allow them to practice from different lengths of the court.

Coach's Cues

"Pizza Position"

"Booger Finger"

"Ear of the Basketball"



RESOURCES AND DRILLS

SHOOTING DRILLS

- 1. Around the World**

1. Place spots/basketballs around the hoop. Each player will go to each spot and make a basket to continue to the next spot. If they miss, they will stay at that spot until the shot is made.
- 2. Horse (Or any animal)**

One player starts the game by calling out a shot they will attempt. If that player makes the shot, all the other players on the team must attempt that same shot. If a player misses the shot, that player receives a letter (H if playing horse). A player is out of the game if they receive all the letters in the animal. If the player misses the original shot, it becomes the next player on the team's turn to call out a shot.
- 3. Layups**

Split your players into two lines at the three point line. Line up half the players with two basketballs on the right side of the three point line, and the other half without basketballs on the left side of the three point line. Players on the right will perform a layup while the players on the left will rebound the ball and pass to a player.
- 4. Knockout**

Players line up in a straight line behind the free throw line. The first two players have basketballs. The first player in line will shoot first, and if the player makes the shot, the player will pass the ball to the third player in line. If the player misses, he must rebound and can shoot from anywhere on the court. This player must make a shot before passing the ball. The second player in line will shoot after the player in front. If the player behind them makes a shot before the first player, then the first player is out.
- 5. Poison**

Similar to knockout. Players line up in a straight line behind the free throw line. The first two players have basketballs. The first player in line will shoot first. If the player makes the first shot, the player will quickly rebound the ball while the other players will run away from the shooting player. Once the shooting player rebounds the ball, they shout "POISON!" Once poison is yelled, all players must freeze. The shooting player will then roll the ball and try to tap the other players. If the ball taps a player, they are out. If the player misses, they must rebound the ball before it bounces 2 times. If it bounces more than twice, the player is out. Once rebounded, the player must shoot and make the shot; then, pass to the next player in line.
- 6. 2 on 1**

For this drill, 2 players are on offense while 1 player is on defense. Starting at half court, the two offensive players must dribble the ball up the court, pass to the open player and shoot at the basket.
- 7. Low Post Shooting**

For this drill, 2 players are on offense. Have all players, but one, line up at half court while the other player is by the basket. Starting at half court, one player will dribble up the court, stop, then pass to the player by the basket. The player by the basket will catch and shoot. Rotate the players: player who dribbled up the court becomes the shooter, the shooter gets in line, and the next person in line becomes the dribbler.



RESOURCES AND DRILLS

HOW TO PASS

1. Ask, "what types of animals live on a farm?" Ideally, a chicken will be named.
2. Next ask, "what sound does a chicken make?" Then, "how does a chicken flap its wings?" Put it all together by telling the players to show you their chicken wings and bawk loudly.
3. Next say, "pick up your basketball by its ears." Players should now be standing with their hands on the ears of the basketball and elbows in the chicken wing position. It is now time to add the "step". Demonstrate how to step with one foot saying, "Step" and "Back." Repeat this 10 times (5 left leg, 5 right leg).
4. Half way through demonstrating the step, begin demonstrating how to extend their chicken wings to simulate the passing motion. Step back bringing the basketball back to the chest.
5. Put it all together in a quick review, "hands on the ears of the basketball, chicken wings, step, pass."

Chest Pass

It is thrown by gripping the ball on the sides with the thumbs directly behind the ball. When the pass is thrown, the fingers are rotated behind the ball and the thumbs are turned down. The resulting follow through has the back of the hands facing one another with the thumbs straight down. The ball should have a nice backspin.

When throwing a chest pass, the players should strive to throw it to the receiver's chest level. Passes that go low to high or high to low are difficult to catch.

Bounce Pass

It should be thrown far enough out that the ball bounces waist high to the receiver. Some say try to throw it 3/4 of the way to the receiver and that may be a good reference point to start. Each player has to experiment how far to throw it so it bounces to the receiver properly. Putting a proper and consistent backspin on the pass will make the distance easier to judge.

Overhead Pass

The overhead pass is often used as an outlet pass. Bring the ball directly above your forehead with both hands on the side of the ball and follow through. Aim for the teammate's chin.

Coach's Cues

"Hands on the ears of the basketball"

"Chicken Wings"

"Step, Pass"



RESOURCES AND DRILLS

PASSING DRILLS

- 1. Partner Pass** Players partner up and line up 3-5 feet apart from each other. Players will face each other and pass the basketball back and forth.
- 2. Monkey in the Middle** Place player in groups of 3-4. The object of the game is for the players on the outside to pass the ball to each other. Place one player in the middle, and their goal is to steal the ball.
- 3. Passing Relay Race** Divide players into 2 teams. Set up cones in two straight lines, and have players at each cone. The players will pass the ball down the line, forward then back.
- 4. Move the Cone** For this drill, have players in pairs. Each pair will have a basketball. Each player should be about 5 feet away from each other. Place a cone in the middle between the 2 players. The object of the game is for the player to hit the cone, thereby moving the cone towards the other player.
- 5. Hot Potato Pass** In this drill, one player is positioned at the center of the key with a basketball. All the other players line up around the 3 point arc. On the coaches command, the player in the key passes the ball to the player to their furthest left, and that player immediately passes back to the player in the center. This back and forth passing continues clock wise. A new player then assumes the center position.
- 6. Shuffle Pass** Player line up in two lines on the baseline about 5-6 feet apart from one another. Players will shuffle to other side passing back and forth.

1. Defense Shuffle

Divide the team into 2 groups. Each group starts at the corner of the court. The first player from each group gets into a defensive stance (feet shoulder width apart, knees bent, arms up and out). On the coaches command, the players start to shuffle their feet. See diagram below.

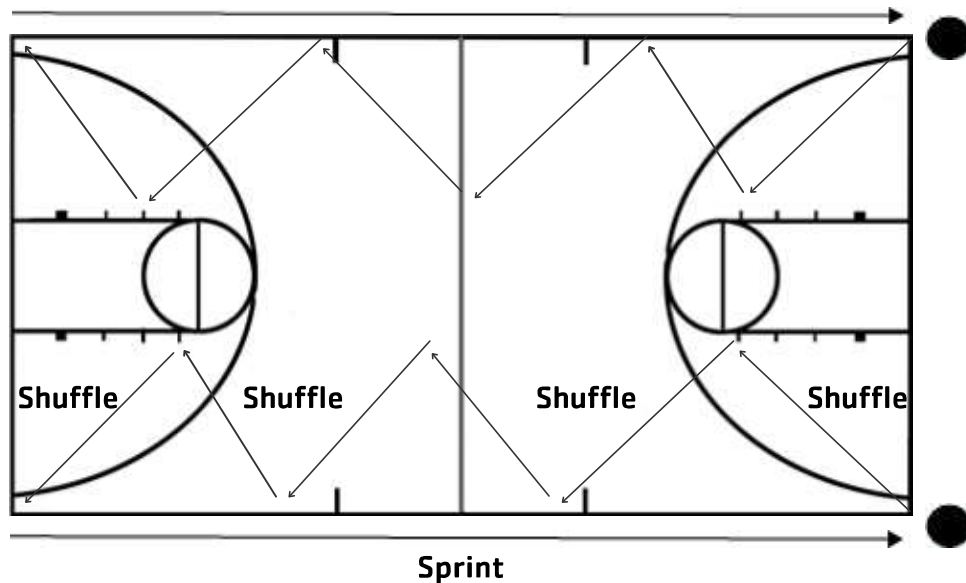

2. 1 on 1 Defense

Divide the team into 2 groups. One group is on offense, and the other group is on defense. Pair up the players so that every offensive player has a player playing defense against them. All the offensive players will have a basketball, and have them line up in a straight line across the half court line facing the basket. The defensive player should lineup about 3 feet away from their partner. The object of the game is for the offensive player to dribble the basketball past an area down court.